

Product information

Where conventional fire detectors reach their physical limits, the SecuriSens ADW 535 line-type heat detector comes into play. The intelligent line-type heat detector works perfectly, even under the most difficult conditions. Whether the fully automatic monitoring of large areas, resisting corrosive gases, extreme humidity and high temperatures, or differentiating between false alarms and real danger – the list of requirements for a state-of-the-art line-type heat detector is both long and detailed.



SecuriSens ADW 535

Line-type heat detector

Design and function

The integrated SecuriSens ADW 535 line-type heat detector combines a proven functional principle with the latest developments in sensor and processor technology.

A sensing tube filled with normal air is installed in the area to be monitored. A fully electronic pressure sensor permanently records the pressure in the sensing tube. This is monitored constantly in the processing electronics and compared with the alarm criteria. Diverse setting options are offered directly on the device via EasyConfig or using the comfortable ADW Config tool for perfect adaptation to existing environmental conditions. The Dynamic Heat Watch (DHW) technology ensures that a brief temperature increase caused by the ambient conditions does not result in a false alarm.

Applications

Thanks to the extremely tough sensing tube, the SecuriSens ADW 535 can be deployed in many applications where conventional fire detectors do not work. With its long service life and maintenance-free design, the ADW 535 is also ideal in applications where detection properties must remain constant over the entire product service life.

Typical applications:

- *Tunnels:* road tunnels, metro and railway tunnels, utility and cable tunnels
- Underground garages, vehicle silos
- Food industry, industrial kitchens, large commercial bakeries
- Alcohol processing, distilleries
- Chemical industry, refineries, oil tanks
- Waste incineration plants
- *Outdoor applications:* loading platforms (flying roofs), historical bridges, fuel warehouses, towers
- *High-temperature applications such as:* paint shops, steel plants, kilns, climate chambers, gas turbines, engine test benches
- And many other applications, e.g. under-floor monitoring in rolling stock, marine applications

Sensing tubes

Depending on the application, various sensing tubes are used (all of which have VdS approval):

- Copper: standard applications, property surveillance
- Stainless steel: food industry and high-temperature applications
- PTFE (Teflon): aggressive ambient conditions (e.g. chemical industry)

- Integrated line-type heat detector for 1 or 2 sensing tubes (Double Tube Technology)
- Based on proven technology
- Fastest heat detector with fully programmable response behaviour plus differential and maximal evaluation
- Intelligent alarm verification with DHW technology (Dynamic Heat Watch)
- Available as standard and Heavy Duty version (with Atex approval)
- Sensing tubes of copper, stainless steel or Teflon withstand extremely severe ambient conditions and high temperatures; can be installed in Ex areas
- High level of functional dependability thanks to fully automatic sensing tube monitoring
- High-performance software: ADW HeatCalc for planning, ADW Config for configuration and maintenance
- EN 54-22 and UL/FM approved

ADW HeatCalc

ADW HeatCalc is used for sketching the sensing tube system and calculating the necessary system settings. The PC tool is rounded off by the parts list and report for the plant documentation.

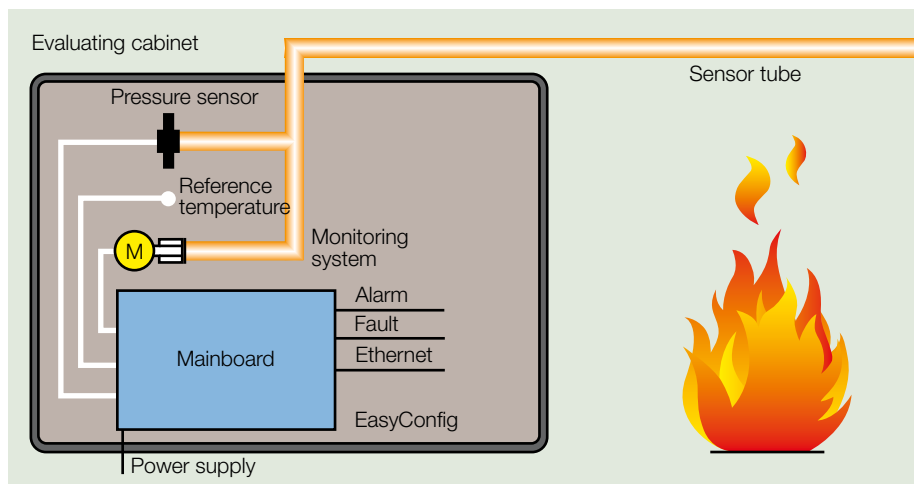

Dimensions ADW 535-1/-2

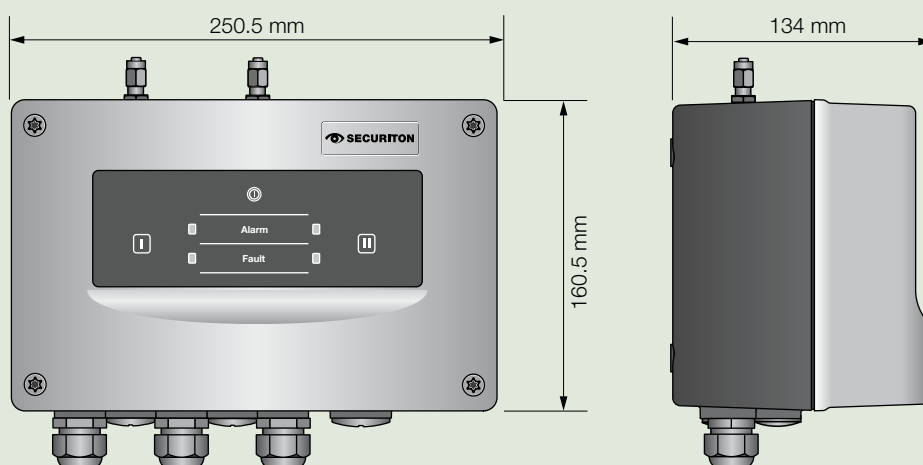

Specifications subject to change without notice. Delivery subject to availability.

Technical data		ADW 535-1	ADW 535-2
Supply voltage range		EN 54/FM/UL 9.0–30 VDC/10.5–29 VDC	EN 54/FM/UL 9.0–30 VDC/10.5–29 VDC
Power consumption (24 VDC) Normal operation		35 mA	43 mA
	Self-test	210 mA (for approx. 180 sec)	230 mA (for approx. 180 sec)
Sensing tubes	Number	1	2
Sensing tube length with/without EN 54-22		max. 115 m/200 m	max. 2 × 115 m/2 × 200 m
Sensing tube monitoring		Automatic self-test monitors sensing tube for leaks, pipe breakage and crushing	
Interfaces	Relay/o. C.	2 (Alarm, Fault)	4 (Alarm I & II/Fault I & II)
	Network/PC tool	Ethernet	Ethernet
	Inputs	Reset, day/night, reference	Reset, day/night, reference
Relay contacts		50 VDC/1 A (UL 30 VDC)	50 VDC/1 A (UL 30 VDC)
Optional modules	max. 4	1 or 2 RIM 36, 1 SIM 35, 1 XLM 35	1 or 2 RIM 36, 1 SIM 35, 1 XLM 35
Standards EN 54-22/FM 3210/UL 521		Classes A1I, A2I, BI, CI, DI, EI, FI, GI	Classes A1I, A2I, BI, CI, DI, EI, FI, GI
Approvals (applied for)	All versions	VdS, CE/DoP, UL, FM	VdS, CE/DoP, UL, FM
	HDx only	Atex	Atex
Operating temp./humidity	Cable terminal	–25 – +70 °C/95% RH, –40 °C auxiliary heating	–25 – +70 °C/95% RH, –40 °C auxiliary heating
	Sensing tubes	–40 – +300 °C/100% RH (material-dependent)	–40 – +300 °C/100% RH (material-dependent)
Housing ADW 535 –1 and –2	Dimensions	250.5 × 160.5 × 134 mm (W × H × D)	250.5 × 160.5 × 134 mm (W × H × D)
	Colour	Light grey RAL 280 70 05, Charcoal RAL 300 20 05	Light grey RAL 280 70 05, Charcoal RAL 300 20 05
	Material, weight	ABS-Blend, UL 94-V0, approx. 1600 g	ABS-Blend, UL 94-V0, approx. 2000 g
	Packaging	262 × 238 × 170 mm (W × H × D)	262 × 238 × 170 mm (W × H × D)
Protection type	EN 60529	IP 65	IP 65
Housing ADW 535 –1HDx and –2HDx	Dimensions	260 × 160 × 134 mm (W × H × D)	260 × 160 × 134 mm (W × H × D)
	Colour	Graphite black RAL 9011	Graphite black RAL 9011
	Material, weight	Duroplast, approx. 2100 g	Duroplast, approx. 2500 g
	Packaging	272 × 238 × 170 mm (W × H × D)	272 × 238 × 170 mm (W × H × D)
Protection type	EN 60529	IP 66	IP 66
Display and operation	LED	1 (green) operation, 1 (red) alarm, 1 (yellow) fault	1 (green) operation, 2 (red) alarm, 2 (yellow) fault
Event memory	Recording	> 16 m. events (installed SD card)	> 16 m. events (installed SD card)
for analogue values		Up to 1 year (installed SD card)	Up to 1 year (installed SD card)

Product line

ADW 535-1/2	Line-type heat detector for 1 or 2 sensing tubes
ADW 535-1/2HDx	Line-type heat detector for 1 or 2 sensing tubes for applications in difficult ambient conditions and Ex areas
RIM 36	Optional module with 5 additional relays
XLM 35	Optional module for connection to SecurLine eXtended
SIM 35	Optional module for RS-485 networking
ADW HeatCalc/ADW Config	PC tool for drawing and calculation/PC tool for commissioning and maintenance
TU 5/4 Cu	Sensing tubes Copper D = 5 mm in 5.5 m rods or on rolls
TU 5/4 St	Sensing tubes Stainless steel D = 5 mm in 6 m rods
TU 6/4 PTFE	Sensing tubes Teflon D = 6 mm on rolls
Fastening	Various pipe clamps made from plastic and metal